

Port Angeles School District
Algebra 1 Benchmark Test Proposal for 2009-2010

Number Properties and Operations

Solve each problem. Choose the best answer for each question and record your answer on the Student Answer Sheet.

1. The Berry Company has \$43,500,000 in total sales for the year. What is this number in scientific notation?
A 43×10^6
B 435×10^6
C 4.35×10^5
D 4.35×10^7
E 4.35×10^6
2. Which equation represents the statement "the length ℓ of the rectangle is five times the width w "?
A $w = 5 + \ell$
B $w = 5\ell$
C $\ell = 5w$
D $\ell = 5 + w$
E $\ell = w - 5$
3. Which statement is false?
A $-6 > -8$
B $3^3 > 4^2$
C $|-6^2| = |7^2 - 13|$
D $-121 < -141$
E $5 \times 3^2 < 6 \times 2^3$
4. Which number has the greatest value?
A 0.137
B 0.46
C 0.3
D 0.2138
E 0.152

5. Evaluate the expression $6 \cdot (4^2 + 6)$.

A 30
B 54
C 84
D 102
E 132

6. Estimate the product 7.38×19.716 by rounding to the nearest one.

A 114
B 120
C 140
D 146
E 160

7. Find the area of this figure, round your final answer to the nearest whole number of square units.

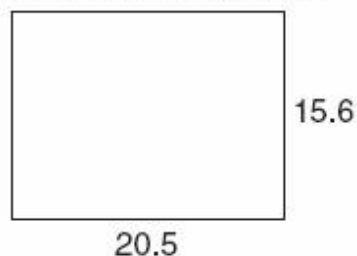

A 72
B 280
C 319
D 320
E 336

8. Martin washed his vehicle exactly once every week for 2 years in a row. How many times did he wash his vehicle during this time period?

A 24 times
B 100 times
C 104 times
D 124 times
E 144 times

Port Angeles School District
Algebra 1 Benchmark Test Proposal for 2009-2010

9. A gym class had 42 students and 7 volleyballs. What was the ratio of volleyballs to students?

- A 1 to 6
- B 6 to 1
- C 1 to 7
- D 7 to 1
- E 1 to 42

10. At the baseball stadium, 3 hotdogs cost \$8.25. At this price, how much will 7 hotdogs cost? Which proportion could be used to solve the problem?

- A $\frac{\$8.25}{3} = \frac{7}{x}$
- B $\frac{\$8.25}{3} = \frac{x}{7}$
- C $\frac{\$8.25}{x} = \frac{7}{3}$
- D $\frac{\$8.25}{3} = \frac{x}{10}$
- E $\frac{\$8.25}{10} = \frac{x}{7}$

11. What is the scale factor for the two similar figures shown below, in simplest form?

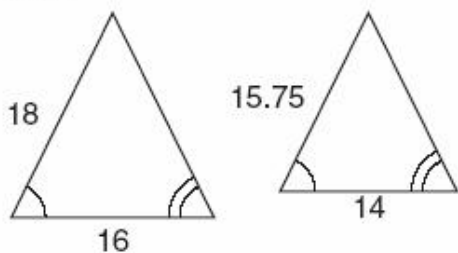

- A 16 to 14
- B 9 to 7
- C 15.75 to 16
- D 8 to 7
- E 9 to 8

12. A ball player makes 538 field goals out of 934 attempts. What percent of his field goals did he make?

- A 28.2%
- B 34.6%
- C 52.2%
- D 57.6%
- E 173.6%

13. What is 32% of 125?

- A 20
- B 32
- C 40
- D 42
- E 44

14. The number 8 is a factor of which of the following numbers?

- A 21
- B 57
- C 81
- D 92
- E 104

15. What is the greatest common factor of 36 and 42?

- A 3
- B 4
- C 6
- D 9
- E 252

16. How much tax is charged to purchase 5 lamps at \$65 each, if the sales tax rate is 8%?

- A \$1.04
- B \$5.20
- C \$10.40
- D \$26.00
- E \$52.00

Port Angeles School District
Algebra 1 Benchmark Test Proposal for 2009-2010

Measurement

17. What is the length of the figure shown?

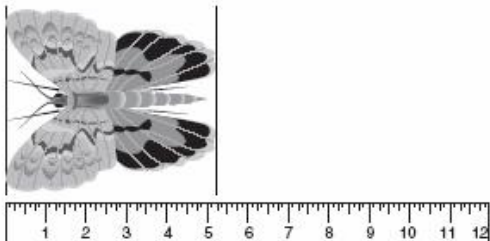

- A 5 inches
 - B 5.125 inches
 - C $5\frac{1}{4}$ inches
 - D 5.375 inches
 - E $5\frac{1}{2}$ inches
18. What is the circumference of a circle with radius 8 inches? (Use 3.14 for π .)

- A 12.56 inches
- B 25.12 inches
- C 50.24 inches
- D 100.48 inches
- E 200.96 inches

19. What is the perimeter of the figure?

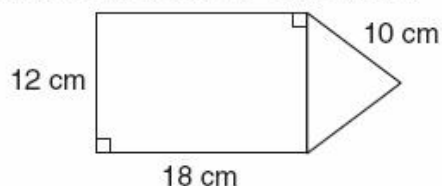

- A 68 cm
- B 74 cm
- C 78 cm
- D 80 cm
- E 112 cm

20. What is the volume, in cubic inches, of a cylinder with a radius of 4 inches and a height of 12 inches? (Use 3.14 for π .)



- A 150.72
- B 301.44
- C 602.88
- D 1205.76
- E 1808.64

21. What is the surface area of the prism?

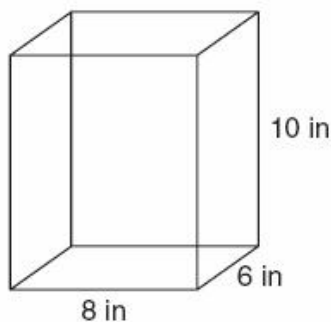

- A 168 square inches
- B 216 square inches
- C 240 square inches
- D 376 square inches
- E 480 square inches

22. Mr. and Mrs. Kingston are installing fence around a rectangular piece of property. The length of the property is 780 yards and the width is 520 yards. How many yards of fencing are needed?

- A 1300 yards
- B 1560 yards
- C 2600 yards
- D 2860 yards
- E 405,600 yards

23. Joel canoes 6.2 miles in 85 minutes. What is his rate in miles per hour?

- A 13.4 mph
- B 6.2 mph
- C 4.3 mph
- D 1.4 mph
- E 0.7 mph

**Port Angeles School District
Algebra 1 Benchmark Test Proposal for 2009-2010**

Geometry

24. What is the transformation from figure 1 to figure 2?

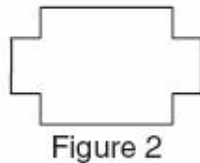
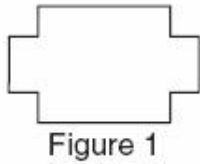

- A slide, turn
- B flip, turn
- C turn
- D slide, slide, turn
- E slide, flip

25. Which type of transformation is shown below?



- A translation
- B rotation
- C reflection
- D glide reflection
- E dilation

26. The figures shown are similar. What is the value of n ?

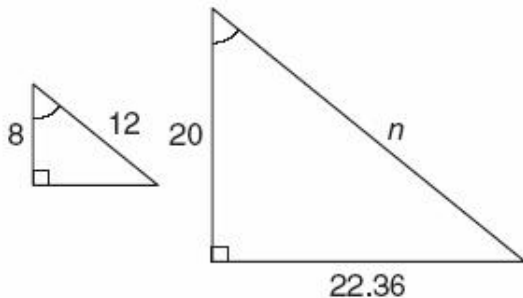

- A 4.8
- B 30
- C 32
- D 48
- E 56

27. What is the value of x ?

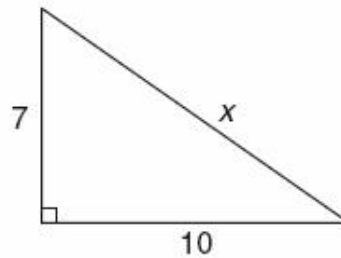

- A 3
- B $\sqrt{149}$
- C $\sqrt{170}$
- D 17
- E 34

28. Which lengths below would form a right triangle?

- A 1, 3, 5
- B 1.2, 2.4, 6.1
- C 6, 9, 10
- D $2\sqrt{5}$, 4, 6
- E $3\sqrt{2}$, $\sqrt{2}$, $\sqrt{2}$

29. The two rectangles are similar. What is the measure of the unknown side? Round your answer to the nearest hundredth.

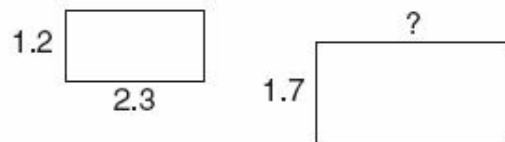

- A 0.89
- B 1.62
- C 2.80
- D 3.26
- E 5.94

30. A right triangle has one leg that is 5 inches longer than the other leg. The hypotenuse is 25 inches long. Find the length of the longer leg.

- A 10 in.
- B 13 in.
- C 15 in.
- D 17 in.
- E 20 in.

Port Angeles School District
Algebra 1 Benchmark Test Proposal for 2009-2010

31. A parallelogram has an area of 180 square inches and the height is 12 inches. What is the length of the base?
- A 6 inches
 B 15 inches
 C 18 inches
 D 90 inches
 E 2160 inches

32. What is the slope of the line?

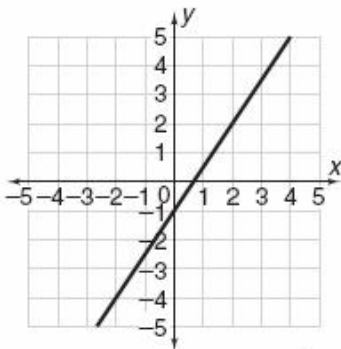

- A -1
 B 1
 C $\frac{2}{3}$
 D $\frac{3}{2}$
 E 2
33. What is the midpoint of $(-8, -4)$ and $(14, 8)$?
- A $(-3, -2)$
 B $(3, 2)$
 C $(-11, -6)$
 D $(11, 6)$
 E $(6, 4)$
34. What is the slope of a line parallel to $4x - 3y = 12$?
- A -4
 B $-\frac{3}{4}$
 C $\frac{1}{4}$
 D $\frac{3}{4}$
 E $\frac{4}{3}$

Data Analysis, Statistics, and Probability

Use the data in the table for Questions 35 to 38.

The data shows the top five ranked men's tennis players, their total earned points, and number of tournaments played.

Player	Points Earned	Number of Tournaments Played
Roddick	3085	20
Federer	6225	18
Hewitt	2490	17
Agassi	2275	17
Nadal	4765	24

35. Who has earned the greatest number of points?
- A Roddick
 B Federer
 C Hewitt
 D Agassi
 E Nadal
36. What is the average number of points Agassi has scored in a tournament?
- A 133.8 points
 B 198.5 points
 C 146.5 points
 D 154.3 points
 E 345.8 points
37. If using the data in the table to construct a bar graph based on the number of tournaments played, the height of which two players would be the same?
- A Federer and Hewitt
 B Nadal and Hewitt
 C Agassi and Roddick
 D Roddick and Nadal
 E Hewitt and Agassi
38. What is the median of the points earned by the top five players?
- A 3085
 B 6225
 C 2490
 D 2275
 E 4765

Port Angeles School District
Algebra 1 Benchmark Test Proposal for 2009-2010

Use the box and whisker plot for Questions 39 and 40.

The Humane Society is tracking the number of puppies born in a litter in a given year.

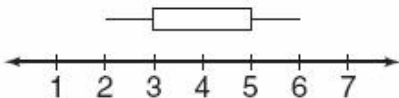

39. What is the first quartile in the distribution of data?
- A 2
 B 3
 C 4
 D 5
 E 6
40. What is the difference between the median and the third quartile?
- A 1
 B 2
 C 3
 D 4
 E 5
41. The caterer for Joan and Matt's wedding has given them a choice of 3 different kinds of meat, 3 kinds of potatoes, 4 vegetables, and 2 soups. How many complete dinners are available to choose from?
- A 12
 B 18
 C 24
 D 36
 E 72

42. Regita collected data on the kind of sandwiches her customers order at her deli shop. The table shows her findings.

Sandwich	Number of Customers
Ham	26
Turkey	25
Chicken	15
Roast Beef	22
Corned Beef	12

Based on this data, what is the probability that the next customer will order a ham sandwich?

- A $\frac{1}{100}$
 B $\frac{21}{100}$
 C $\frac{13}{50}$
 D $\frac{1}{2}$
 E $\frac{67}{100}$
43. Which of the following is a possible sample space for this experiment?



- A {1, 2, 3, 4, 5}
 B {Roy, Becky, George}
 C {head, tails}
 D {Roy, Yolanda, Paul, George, Becky, Walt}
 E {1, 4, heads, tails}

Port Angeles School District
Algebra 1 Benchmark Test Proposal for 2009-2010

50. What are the coordinates of point C?

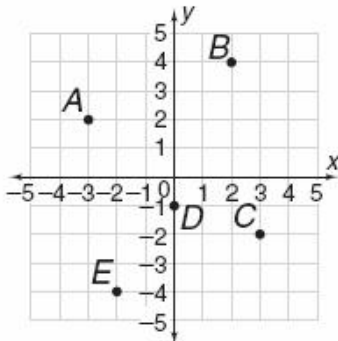

- A (-3, 2)
- B (0, -1)
- C (2, 4)
- D (3, -2)
- E (-2, -4)

51. Plot and connect the given points in order, and determine the perimeter of the figure.

- $(-4, 2)$, $(-2, 2)$, $(-2, 4)$, $(1, 4)$, $(1, 3)$,
 $(3, 3)$, $(3, -4)$, $(-4, -4)$

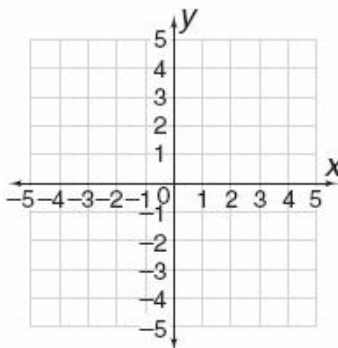

- A 24
- B 26
- C 30
- D 32
- E 36

52. Which of the following is the equation of $y = -4x - 3$ shifted 4 units down?

- A $y = -4x + 1$
- B $y = -4x - 7$
- C $y = 4x - 7$
- D $y = 4x + 1$
- E $y = -4x - 8$

53. Which graph represents the solution of $2x + 12 > 16$?

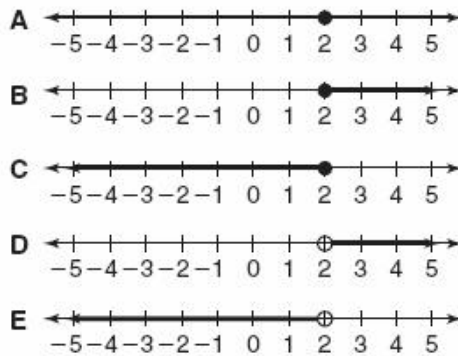

54. Simplify: $\frac{4x^2\sqrt{6^2 + 8^2}}{8x}$

- A $5x$
- B $10x$
- C $0.5x$
- D $30x$
- E $20x$

55. Which expression is equivalent to $-3(b^2 - 4b)$?

- A $3b^2 + 4b$
- B $-3b^2 - 12b$
- C $9b^2 + 12b$
- D $-3b^2 + 4b$
- E $12b - 3b^2$

56. Which expression is the completely factored form of $x^3 - x^2 - 26x + 30$?

- A $(x + 5)(x^2 - 4x + 6)$
- B $(x - 5)(x^2 + 4x - 6)$
- C $(x + 5)(x^2 + 4x - 6)$
- D $(x - 5)(x^2 - 4x + 6)$
- E $(x + 5)(x^2 - 4x - 6)$

Port Angeles School District
Algebra 1 Benchmark Test Proposal for 2009-2010

57. Which graph is the solution to the system of equations?

$$y = x - 2$$

$$2x - 3y = -9$$

A

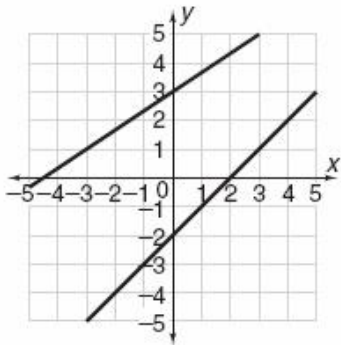

B

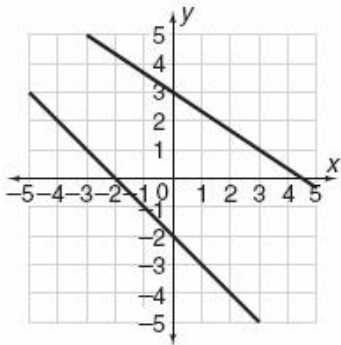

C

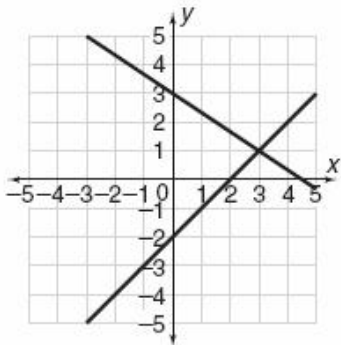

D

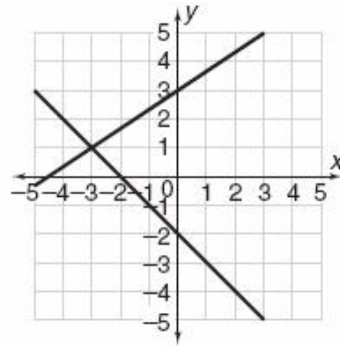

E

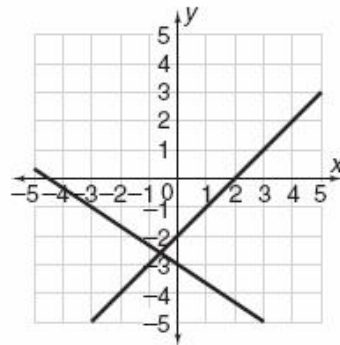

58. What is the x-value in the following system?

$$3x - 2y = 1$$

$$x + 2y = 11$$

A 0

D 3

B 1

E 4

C 2

59. What is the value of m in the matrix?

$$\begin{bmatrix} 6 & -2 \\ m & 0 \end{bmatrix} = \begin{bmatrix} n & -2 \\ -4 & 0 \end{bmatrix}$$

A $m = -4$

D $m = 4$

B $m = -2$

E $m = 6$

C $m = 0$

60. What is the value of y in the matrix below?

$$\begin{bmatrix} -12 & 10 & -11 \\ 10 & 11 & 12 \end{bmatrix} + \begin{bmatrix} 8 & 6 & -5 \\ -8 & 6 & 5 \end{bmatrix} = \begin{bmatrix} 4 & 16 & -16 \\ 2 & y & 17 \end{bmatrix}$$

A -16

D 16

B -6

E 17

C 4